

Tradewinds Tornado High Tension Parasol

Instructions and Safety notices

Note: These instructions should be delivered with the Parasols and should be retained by the operator.

Please ensure that these instructions are read prior to the installation of the parasols or bases.



www.Tradewinds.co.za

Table of Contents

Before you start	3
Positioning of the ground base	3
Unpacking and checking of the ground base	4
Electrical planning	4
Installation	5
Ground base installation	5
Foundation dimensions	5
Curing of concrete	6
Erection of the parasol	7
Operation	8
Opening	8
Closing	8
Storage	8
Safety	9
Maintenance	9
Cleaning	9
Spares	9
Safety Notices	10
Bases	10
Moving Parasols	10
Parasols with Electrics	10
Heaters	11
Product Warranty	11
Tornado Frame Diagram	12

Before you start

Before attempting any installation of the bases or the parasols, please ensure that you have read and understand the instructions fully.

Please note that Tornado Parasols are very heavy (more than 100Kg) and that precautions need to be taken before attempting to move the parasols.

Do not unpack the parasol until the base has been installed, the concrete allowed to cure fully and you are ready to erect the parasol.

Positioning of the ground base

When positioning the ground base please take note of any surrounding walls and overhanging objects.

The edge of the canopy should be no closer than 200mm to the nearest solid object. Positioning the parasol closer than this recommended distance can cause the damage to the parasol frame, canopy and any item the parasol may come into contact with.

When positioning multiple Tornado parasols adjacent to each other there should be a gap of 56mm between the edges of the canopies.

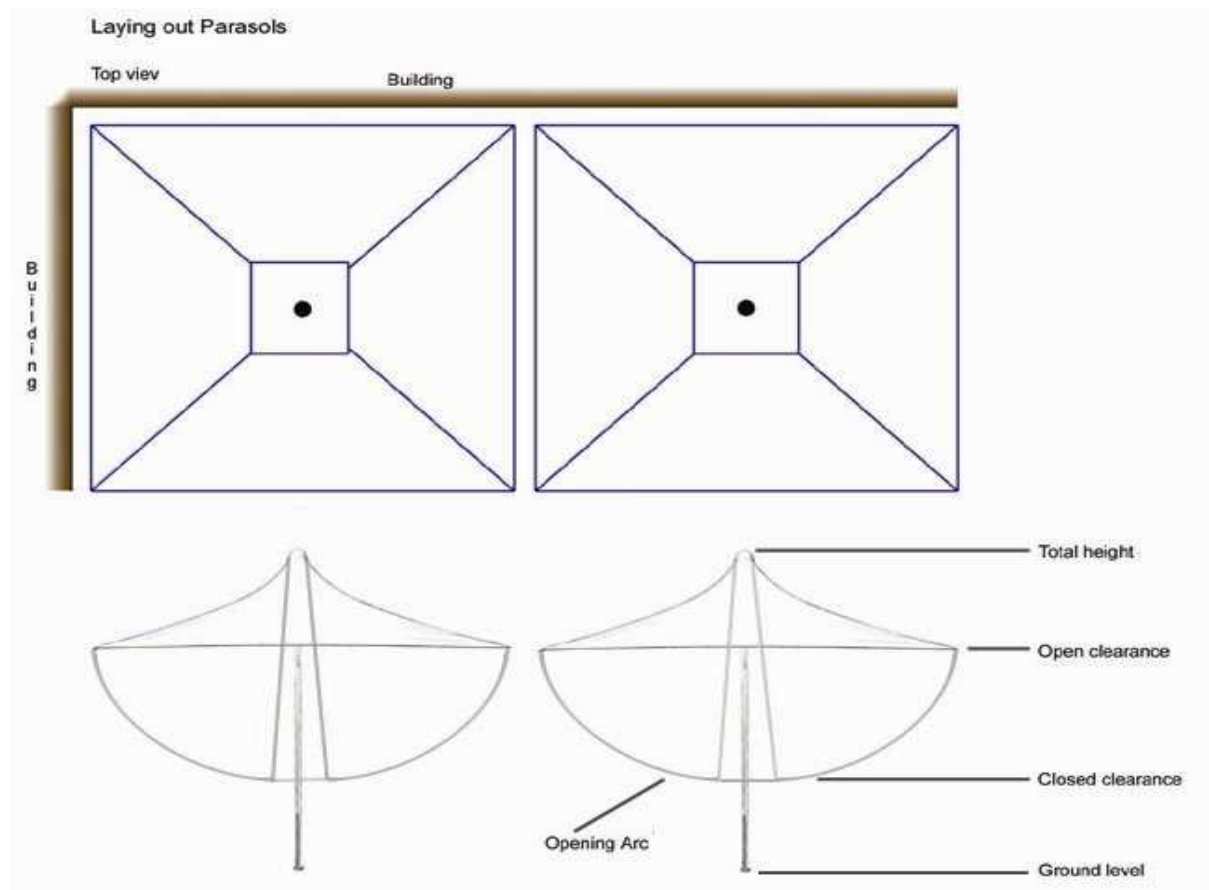

Guttering systems are available to connect Tornado parasols together.

It is not possible to connect Tornado parasols of different sizes together using guttering systems.

Unpacking and checking of the ground base.

Remove the ground base from its packaging and open one end of the Tornado packaging, to gain access to the bottom of the main pole. Slide the Tornado out the tube so that about 40cm of pole is clear of the tube.

Take the ground base and slide it over the tube to check the fit and also check that the holes on the base and the Tornado can be lined up correctly. Should any adjustment need to be made it should be done at this stage, rather than when the ground bases are installed.

Once you are sure that the holes align correctly remove the ground base and push the Tornado back into the tube fully and reseal.

Electrical planning

Tornado parasols can be fitted with lights, heaters, screens, speakers and other electrical components.

Should you be planning to fit any electrical appliance the following should be noted

Electrical power will need to be fed to the parasol, through the ground base and up the central core of the parasol.

Electrical cabling placed in the ground should be correctly specified and protected. Please consult an electrician to ensure that the required standards are adhered to.

Electrical cable will need to be run through the ground and through the concrete used for the in ground base foundations.

It may be a good option to lay a conduit to take electrical cables, this would allow flexibility to later fit cables, subject to requirements.

Should you wish to fit speakers, the speaker cable may need to be shielded from electrical cables.

Installation

Ground base installation

Once the exact position of the ground base is decided upon the ground bases can be installed as follows.

Tornado parasols require substantial concrete footings to ensure stability. Holes need to be dug to accommodate at least the following footing dimensions.

Should there be any doubt about the suitability and stability of the surrounding soil, the sizes of the footings may need to be increased. Professional help and advice should be sought if required.

Foundation dimensions

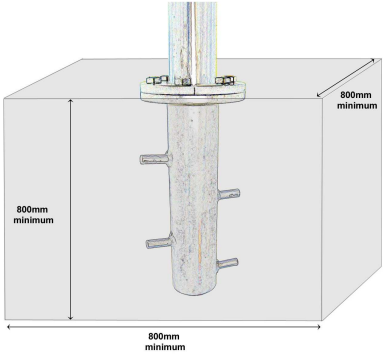
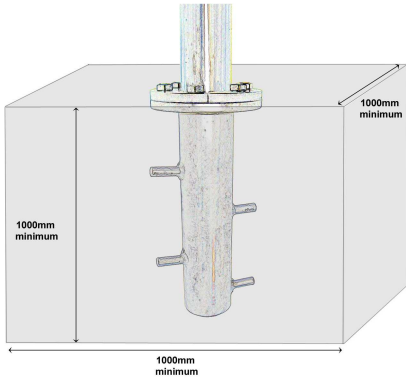
2.8m Square	4.2m Square
	
800mm x 800mm x 800mm	1000mm x 1000mm x 1000mm

Use a straight timber plank at least as wide as the top of the in ground base (+/- 200mm) and wider than the concrete footings. Place the In ground base, upside down, in the centre of the plank. Mark the position of two, opposite holes in the base on the plank and remove the in ground base.

Drill two holes through the marked positions of the plank. Place the base back onto the plank and bolt the ground base to the plank (from the top of the ground base)

Place the plank, with the in ground base attached to the underside of the plank, into the hole as per the diagram.

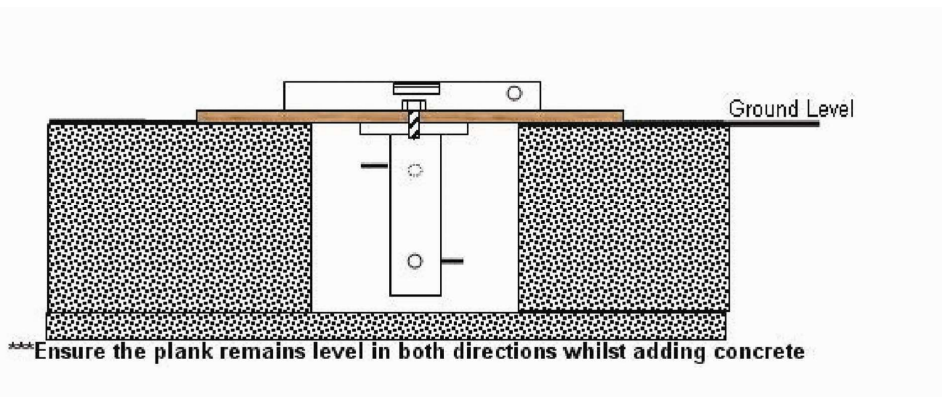

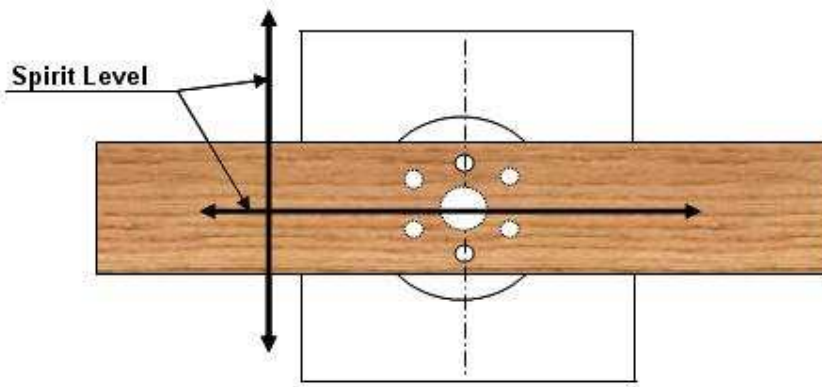

ANY ELECTRICAL CABLE AND POWER SUPPLY TO THE PARASOL SHOULD HAVE BEEN FITTED BEFORE MOVING ON TO NEXT STAGE OF INSTALLATION.

Using a spirit level on top of the plank, ensure that the plank is level IN BOTH DIRECTIONS.

Fill the hole, from both sides of the plank, with concrete, continuously checking that the plank remains level in both directions.

DO NOT ALLOW THE CONCRETE TO FILL THE IN GROUND BASE.

Curing of concrete

Concrete should be left to cure for at least 3 days prior to erection of the parasols. This can be subject to prevailing weather conditions and in damp, cold or humid environments it can be necessary to allow the concrete to cure for longer periods of time. Local advice may need to be sought, to ensure correct curing times.

Erection of the parasol

Once the concrete has cured fully the parasol can be fitted to the ground base.

Completely remove the tornado from the packaging and rest it on a flat level surface off the ground, ideally steel trestles, which allow access to fit any wiring, lights and the lid of the parasol.

Make sure that the base of the parasol is near the in ground base.

If any electrical components are going to be fitted you will need to have a qualified electrician on site at this time.

Feed any cables that have been left at the ground base through the entire length of the parasol.

Electrical connections of the lights should be made at this time, before erecting the parasol.

Once the electrical connections are completes the lid should be fitted to the top of the parasol.

This is attached with 4 bolts and washers.

To place the parasol into the ground base, lower the bottom of the parasol towards the ground base and raise the top towards the vertical. As the parasol reaches the vertical it should be gently lowered into the base.

The parasol can be rotated so that the arms open in the direction required.

The bolts should be fitted to secure the parasol to the ground base. When initially installing the parasol do not tighten the bolts completely as you might need to turn the parasol to line up the canopy correctly.

Operation

Opening

Please check that Tornado is correctly bolted into the base before attempting to open the parasol.

Gently ease the struts outwards whilst pulling down on both pulley ropes until the Tornado canvas becomes taut as it moves upwards.

Undo the temporary ties around the 4 – support struts allowing them to swing free.

Now slacken the pulleys sufficiently to allow the stiffener arms to be fitted into the two connecting wings situated on the main mast.

Insert all the bolts BUT DO NOT TIGHTEN THE NUTS.

Once these stays are in place, pull down on both the ropes until the canvas becomes ridged.

Continue pulling down on the pulley ropes; this will cause the tension spring to compress and move down past the first hole on the main mast. See Tension Spring detailed Drawing on page 12.

Once the hole is visible insert the pin.(use a stepladder)

The ropes can now be released slowly until the pulleys become slack.

The pulley systems can now also be removed if required.

Please store the pulleys in a safe place as you will need these to close the parasol.

All the bolts can now be tightened on the strut connectors.

Finally rotate the whole parasol to line up the canopy correctly and tighten the bolts on the base.

Closing

To close the Tornado it is necessary to reinstall the pulley system.

Once the pulleys are installed, pull down on both pulley ropes to compress the tension spring sufficiently and remove the pin above the tension spring flange.

Slacken the pulley ropes and then remove the bolt from the bottom of each of the supporting struts.

Tie or tape the supporting struts to the long main struts.

Continue to slacken the pulley ropes until the Tornado closes.

Storage

Should the parasol be left closed for any length of time we would recommend the use of a cover bag to protect the canopy. If parasols are to be removed from the base and stored they should be completely dry and suitably protected with a cover bag.

Safety

In cases where severe weather warnings are issued, the umbrella should be closed prior to the onset of such conditions.

PLEASE BE AWARE THAT ANY DAMAGE CAUSED BY WIND IS NOT COVERED UNDER WARRANTY.

Please ensure that all heaters are allowed to cool and removed from the parasol before any attempt is made to close it.

HEATERS LEFT INSIDE PARASOLS THAT ARE CLOSED CONSTITUTE A FIRE RISK.

HEATERS MUST BE REMOVED BEFORE CLOSING THE PARASOL.

Lights can be left inside the parasol when closed, but must be turned off at all times when the parasol is not fully open.

Maintenance

Parasols are not designed to be permanent shelters and as such should regularly be inspected for wear and damage.

Check bolts on bases for tightness and visually check all connecting points on the struts of the parasol to ensure that the bolts are correctly sited and nuts and washers are in place.

Do not continue to use any parasol that shows signs of damage or wear. You should immediately contact your supplier. Damaged parasols should be closed until the fault is rectified.

Cleaning

The frame can be cleaned with a damp sponge or cloth, using a mild soap solution, Dry with a soft cloth.

If the surface of the Stainless steel shows signs of tarnishing or rusting (this is normal) and can be removed with a fine wire wool.

The canopy fabric can be cleaned using either a soft brush, to remove dust and dry soil, or washed down with clean, lukewarm water, to ensure that dirt does not become ingrained in the fabric. If a thorough cleaning is required, sponge over the fabric using a mild (2%) soap solution. Rinse well with plenty of water to remove all soap residues.

Should the surface of the PVC canopy become damaged it is possible to carry out minor repairs using a liquid PVC paint. This is available from many marine specialists. Note : when applying this paint use in very small quantities and apply using cotton buds.

Spares

If there is any need for spares please contact your parasol supplier or Global Parasols directly.

Safety Notices

The following notices should be read carefully. They can also assist with the production of any required risk assessment documentation that might be required.

Bases

We strongly advise that these high tension parasols only be bolted to concrete in ground bases. Parasols used without bases, bases that are too light, or not correctly fitted, can be a hazard.

Please ensure that any holding system used is proportionate to the size of the parasol and correctly fitted.

You should regularly check to ensure that the bolts used in any base or ground base are tightened correctly.

Where parasols are used with in-ground fittings ensure that there is no movement in the ground base and that when the parasol is up it is absolutely vertical.

Moving Parasols

Be aware that if moving parasols they are large and heavy items. Removing them from bases or ground fittings should be carried out with care to ensure that there is no risk of injury or risk damage to the parasol.

You should only ever attempt to move parasols when in the closed position. Parasols should be folded down completely; the fabric should be wrapped correctly round the frame, strapped and have a cover bag or transport bag fitted before they are carried.

Always carry parasols when in a horizontal position, never try and carry a parasol when vertical.

Up to 8 people can be needed to move large parasols safely. You also need to be aware that the weight distribution is not even along the length of the parasol. It is likely that the top of the parasol will be heavier than the bottom. Please ensure that you are certain of weight distribution before undertaking a lift

Parasols with Electrics

If parasols with integrated heating and lighting are fitted please ensure that installation instructions have been followed correctly.

IMPORTANT - heaters and lights should be individually protected by an RCD and also be switched or controlled by suitable PIR sensors

Heaters

Please ensure that the power to the parasols is switched off before connecting or disconnecting any heaters.

Heaters should always be removed from parasols before closing the canopy. Before heaters are removed they should be allowed to fully cool before any attempt to remove them. Heaters should be left for a period of 20 minutes to cool down before any attempt is made to remove them. Please check carefully, after 20 minutes, starting at the back of the heater, that the whole unit is fully cooled before removing it. It is not necessarily possible to tell if a heater is hot from visual inspection.

Light units can be left in the parasol when closed.

Heaters should be mounted on the parasols at a height that is out of reach, ideally at a height of 2.4m from the ground. As such great care needs to be taken when removing heaters from parasols. You will need steps to reach the heaters and all sensible, usual precautions should be adhered to when using steps. These steps will need to be at a height that enables easy reaching of the heater brackets. Steps should be moved round the parasol to remove each heater, rather than trying to reach around the side of the pole to remove heaters from the opposite side.

The effort required to remove the heaters is worthwhile. Following the guidelines above reduces the risk of damage to the canopy that can be caused by hot heaters and also damage to the heaters if they are dropped or knocked.

Product Warranty

Tornado High Tension umbrellas are guaranteed, from original date of purchase by the initial buyer, for a period of 1 year against defects in metal fixtures & fittings and against defects resulting from faulty workmanship. Although the manufacturer strives to provide the highest quality, we accept no responsibility for defects in fading of fabric or fabric print degradation. The manufacturer will not be liable for any extra costs incurred by the buyer as a result of defects found in the product or as a result of faulty product, over and above those covered in the guarantee contained in the paragraph above.

Tradewinds products are covered by a full spares backup from our international dealer network.

:

Tornado Frame Diagram

